

## Overview

The SIGA-UM and SIGA-MAB are Universal Class A/B Modules. They are intelligent analog Addressable devices that are part of GE Security's Signature Series system. The actual function of the module is determined by the "personality code" selected by the installer. This is downloaded to the module from the Signature loop controller during system configuration. The SIGA-UM and SIGA-MAB gather analog information from the slave devices connected to them and convert this into digital signals. Each module's on-board microprocessor measures and analyzes the signal and decides whether or not to input an alarm.

**The SIGA-UM** is installed to a standard North American 2-gang electrical box, making it ideal for locations where only one module is required. Separate I/O and data loop connections are made to each module. The SIGA-UM may be used to connect any one of the following:

- two Class B or one Class A Initiating Device Circuits
- one Class A or B Notification Appliance Circuit
- one Class A or B Circuit for 2-wire Smoke Detectors
- one Form "C" (NO/NC) Dry Output Contact Relay

**The SIGA-MAB** is part of the UIO family of plug-in Signature Series modules. It takes advantage of the modular flexibility and easy installation that characterizes all UIO modules. Two- and six-module UIO motherboards are available. These can accommodate individual risers for each on-board module, or shared risers in any combination with their UIO modules. All wiring connections are

made to terminal blocks on the motherboard. UIO assemblies may be mounted in GE Security enclosures. The SIGA-MAB may be used to connect any one of the following:

- one Class B or one Class A Initiating Device Circuit
- one Class A or B circuit for 2-wire Smoke Detectors
- one Class A or B Notification Appliance Circuit

## Standard Features

- **15 modules in one**  
Multiple applications including Class A or B device circuit wiring, Class A or B 2-wire smoke detector circuits and delayed latching (retard) for waterflow alarm applications. The installer selects one of up to 15 "personality codes" to be downloaded from the loop controller.
- **Plug in (UIO) or standard 2-gang mount**  
UIO versions allow quick installation where multiple modules are required. The 2-gang mount version is ideal for remote locations that require a single module.
- **Automatic device mapping**  
Signature modules transmit information to the loop controller regarding their circuit locations with respect to other Signature devices on the wire loop.
- **Electronic addressing**  
Programmable addresses are downloaded from the loop controller, a PC, or the SIGA-PRO Signature Program/Service Tool. There are no switches or dials to set.

# Class A/B Modules

Model SIGA-UM, SIGA-MAB



SIGA-MAB

SIGA-UM

Patented



**Intelligent device with microprocessor**

All decisions are made at the module to allow lower communication speed with substantially improved control panel response time and less sensitivity to line noise and loop wiring properties; twisted or shielded wire is not required.

**Non-volatile memory**

Permanently stores serial number, type of device, and job number. Automatically updates historic information including hours of operation, last maintenance date, number of alarms and troubles, and time and date of last alarm.

**Stand-alone operation**

The module makes decisions and inputs an alarm from initiating devices connected to it even if the loop controller's polling interrogation stops. Function availability dependant upon control panel.

**Ground fault detection by address**

Detects ground faults right down to the device level.

**High ambient temperature operation**

Install in ambient temperatures up to 120oF (49oC).

**Designed to ISO 9001 standards**

All Signature products are manufactured to strict international quality standards to ensure highest reliability.

## Installation

**The SIGA-UM:** mounts to North American 2-1/2 inch (64 mm) deep 2-gang boxes and 1-1/2 inch (38 mm) deep 4 inch square boxes with 2-gang covers and SIGA-MP mounting plates. The terminals are suited for #12 to #18 AWG (2.5 mm<sup>2</sup> to 0.75 mm<sup>2</sup>) wire size.

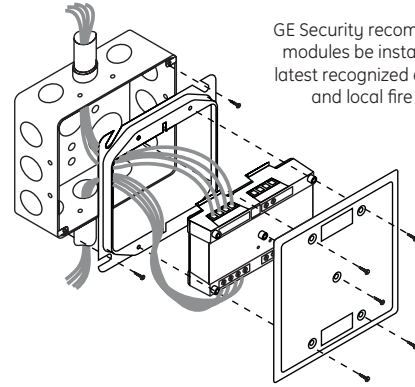

GE Security recommends that these modules be installed according to latest recognized edition of national and local fire alarm codes.

**SIGA-MAB:** mount the UIO motherboard inside a suitable GE Security enclosure with screws and washers provided. Plug the module into any available position on the motherboard and secure the module to the motherboard with the captive screws. Wiring connections are made to the terminals on the motherboard (see wiring diagram). UIO motherboard terminals are suited for #12 to #18 AWG (2.5 mm<sup>2</sup> to 0.75 mm<sup>2</sup>) wire size.

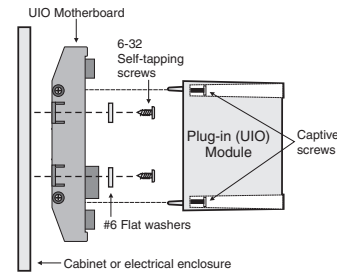

**Electronic Addressing** - The loop controller electronically addresses each module saving valuable time during system commissioning. Setting complicated switches or dials is not required. Each module has its own unique serial number stored in its "on-board memory". The loop controller identifies each device on the loop and assigns a "soft" address to each serial number. If desired, the modules can be addressed using the SIGA-PRO Signature Program/Service Tool.

## Compatible Smoke Detectors

Manufacturer	Model	Description	Base	Max #
System Sensor	1451	Ion	B401(B)	10
System Sensor	2451	Photo	B401(B)	10
GE Security	6250B	Ion	6251B-001A	20
GE Security	6270B	Photo	6251B-001A	15
GE Security	EC30U	Photo	CSBU-1	16

## Testing & Maintenance

The module's automatic self-diagnosis identifies when it is defective and causes a trouble message. The user-friendly maintenance program shows the current state of each module and other pertinent messages. Single modules may be turned off (de-activated) temporarily, from the control panel.

Scheduled maintenance (Regular or Selected) for proper system operation should be planned to meet the requirements of the Authority Having Jurisdiction (AHJ). Refer to current NFPA 72 and ULC CAN/ULC 536 standards.

## Module Operating Characteristics

Mode of Operation	Personality Code	Standby Current	Alarm Current	EOL Resistor Value
Class B Initiating Device Circuit (IDC)	1, 2, 3, 4	396µA	680µA	47K ohm
Form "C" Dry Contact Relay - Note 1	8	100µA	100µA	N/A
Class A Initiating Device Circuit (IDC)	9, 10, 11, 12	223µA	365µA	47K ohm
2-Wire Smoke Detectors and Initiating Devices (IDC)	13, 14, 20, 21	2mA	First - 17mA Subsequent - 100µA	15K ohm
Class A or B Notification Appliance Circuit (NAC) - See Note 1	15, 16	223µA	365µA	47K ohm (Class B)

**Note 1:** Contacts rated at 2 amps @ 24 Vdc, 0.5 amps @ 120 Vac (or 220 Vac non-UL), 50W @ 25 V audio, 35W @ 70 V audio.

## Warnings & Cautions

This module will not operate without electrical power. As fires frequently cause power interruption, we suggest you discuss further safeguards with your fire protection specialist.

## Compatibility

The Signature Series modules are compatible only with GE Security's Signature Loop Controller.

## Application (Personality Codes)

The actual duty performed by the SIGA-UM and SIGA MAB is determined by its sub-type code or "Personality Code". The code is selected depending upon the desired application by the installer and is downloaded from the loop controller.

Code	Class	Description		Suitable for ...	
1	B	Normally Open Alarm	Latching	Assign to one or both circuits. Configures either 1 or 2 or both for Class B normally-open dry contact initiating devices. An ALARM signal is sent to the loop controller when the input contact is closed. The condition alarm is latched at the module.	Pull Stations, Heat Detectors
2	B	Normally Open Alarm	Delayed Latching	Assign to one or both circuits. Configures either circuit 1 or 2 or both for Class B normally-open dry contact. An ALARM signal is sent to the loop controller when the input contact is closed for at least 16 seconds. The condition alarm is latched at the module.	Waterflow Alarm Switches
3	B	Normally Open Active	Non-Latching	Assign to one or both circuits. Configures either circuit 1 or 2 or both for Class B normally-open dry contact monitoring input. An ACTIVE signal is sent to the loop controller when the input contact is closed. The active condition is not latched at the module.	Fans, Dampers, Doors
4	B	Normally Open Active	Latching	Assign to one or both circuits. Configures either circuit 1 or 2 or both for Class B normally-open dry contact monitoring input. An ACTIVE signal is sent to the loop controller when the input contact is closed. The active condition is latched at the module.	Supervisory and Tamper Switches
8 <sup>1</sup>		Control Relay		Applies to both circuits 1 and 2 simultaneously. Configures module to provide one Form "C" DRY RELAY CONTACT. Contact rating is 2.0 amp @ 24 Vdc; 0.5 amp @ 120 Vac (or 220 Vac non-UL). This Personality Code is available with the SIGA-UM only.	Door Closers, Fans, Dampers
9	A	Normally Open Alarm	Latching	Applies to both circuits 1 and 2 simultaneously. Configures module for Class A normally-open dry contact initiating devices. An ALARM signal is sent to the loop controller when the input contact is closed. The alarm condition is latched at the module.	Pull Stations, Heat Detectors
10	A	Normally Open Alarm	Delayed Latching	Applies to both circuits 1 and 2 simultaneously. Configures module for Class A normally-open dry contact initiating devices. An ALARM signal is sent to the loop controller when the input contact is closed for at least 16 seconds. The alarm condition is latched at the module.	Waterflow Alarm Switches
11	A	Normally Open Active	Non-Latching	Applies to both circuits 1 and 2 simultaneously. Configures module for Class A normally-open dry contact monitoring input. An ACTIVE signal is sent to the loop controller when the input contact is closed. The active condition is not latched at the module.	Fans, Dampers, Doors
12	A	Normally Open Active	Latching	Applies to both circuits 1 and 2 simultaneously. Configures module for Class A normally-open dry contact monitoring input. An ACTIVE signal is sent to the loop controller when the input contact is closed. The active condition is latched at the module.	Supervisory and Tamper Switches
13	B	2-Wire Smoke	Alarm Non-Verified	2-wire Smoke Detectors that DO NOT require alarm verification. Normally open dry contact initiating devices. CAN be on the same circuit with personality code 13 ONLY. An ALARM signal is sent to the loop controller when the input contact is closed or a smoke detector enters into alarm. The alarm condition is latched at the module. The LED on only the first smoke detector to alarm will latch ON steady. Circuit B is used to monitor smoke power from the loop controller. Compatible smoke detectors include: up to 20 - 6249/6250/6264 series, or up to 15 - 6266/6269/6270 series. Also compatible with up to 10 - model 1451 or 2451 detectors.	Smoke Detectors, Pull Stations, Heat Detectors
14	B	2-Wire Smoke	Alarm Verified	Applies to both circuits 1 and 2 simultaneously. Configures module for connection of up to 1.0 mA of conventional 2-wire Smoke Detectors that DO require alarm verification. Normally open dry contact initiating devices. CAN NOT be on the same circuit. An ALARM signal is sent to the loop controller when a smoke detector enters into alarm. The alarm condition is latched at the module. The LED on only the first smoke detector to alarm will latch ON steady. Circuit B is used to monitor smoke power from the loop controller. Compatible smoke detectors include: up to 20 - 6249/6250/6264 series, or up to 15 - 6266/6269/6270 series. Also compatible with up to 10 - model 1451 or 2451 detectors.	Smoke Detectors, Pull Stations, Heat Detectors
15	A	Signal Output		Applies to both circuits 1 and 2 simultaneously. Configures module for connection of Class A Notification Appliance Circuit (NAC). The maximum allowable signal power is 2 amps @ 24 Vdc, 0.5 amps @ 120 Vac (or 220 Vac non-UL). The maximum allowable speaker power is 50W (25 V audio) or 35W (70 V audio).	Horns, Speakers
16	B	Signal Output		Applies to both circuits 1 and 2 simultaneously. Configures module for connection of Class B Notification Appliance Circuit (NAC). The maximum allowable signal power is 2 amps @ 24 Vdc, 0.5 amps @ 120 Vac (or 220 Vac non-UL). The maximum allowable speaker power is 50W (25 V audio) or 35W (70 V audio).	Horns, Speakers
20	A	2-Wire Smoke	Alarm Non-Verified	Operates the same as personality code 13, except that the wiring is Class A.	Smoke & Heat Detectors, Pull Stations
21	A	2-Wire Smoke	Alarm Verified	Operates the same as personality code 14, except that the wiring is Class A.	Smoke & Heat Detectors, Pull Stations

**Notes:** Personality codes are assigned to each address. Only codes 1, 2, 3 and 4 can be mixed on any one module. For example, personality code 1 can be assigned to the first address (circuit A) and code 4 can be assigned to the second address (circuit B). All other codes automatically use up both addresses simultaneously and therefore cannot be mixed.

<sup>1</sup> Does not apply to SIGA-MAB.

## Typical Wiring (SIGA-UM)

Modules will accept #18 AWG (0.75mm<sup>2</sup>), #16 (1.0mm<sup>2</sup>), #14 AWG (1.50mm<sup>2</sup>) and #12 AWG (2.50mm<sup>2</sup>) wire sizes. Note: Sizes #16 AWG (1.0mm<sup>2</sup>) and #18 AWG (0.75mm<sup>2</sup>) are preferred for ease of installation. See Signature Loop Controller catalog sheet for detailed wiring requirement specifications.

### Class B Dual Input Module (Personality Code 1, 2, 3 or 4)

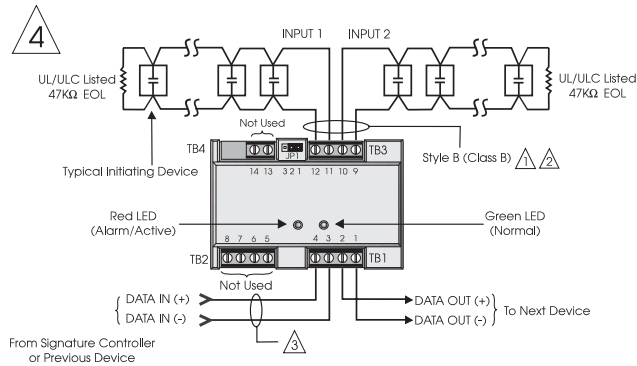

### Control Relay Module (Personality Code 8, SIGA-UM only)

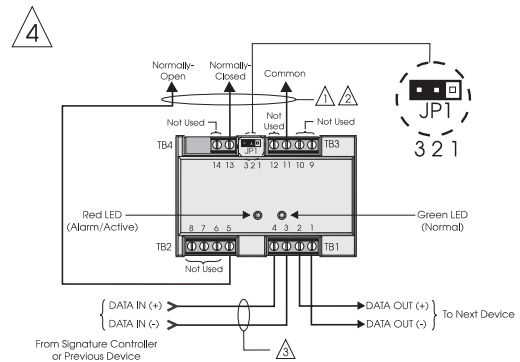

### 2-Wire Smoke Detectors - Class A or Class B (Personality Code 13, 14, 20 or 21)

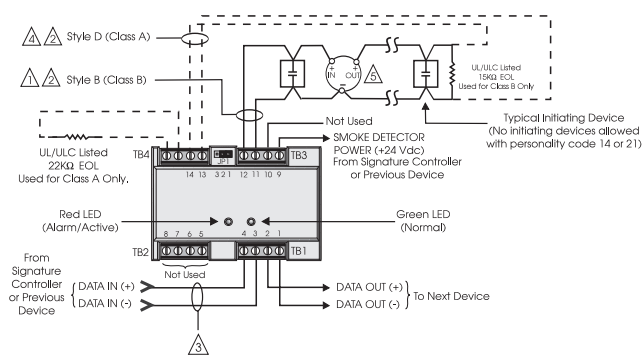

### Single Output Module (Personality Code 15 or 16)

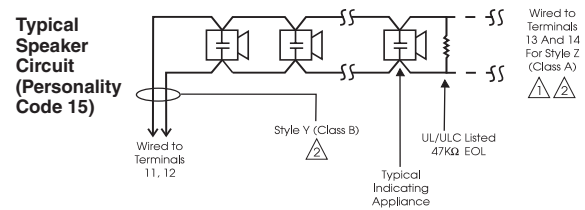

### Typical Notification Appliance Circuit (Personality Code 16)

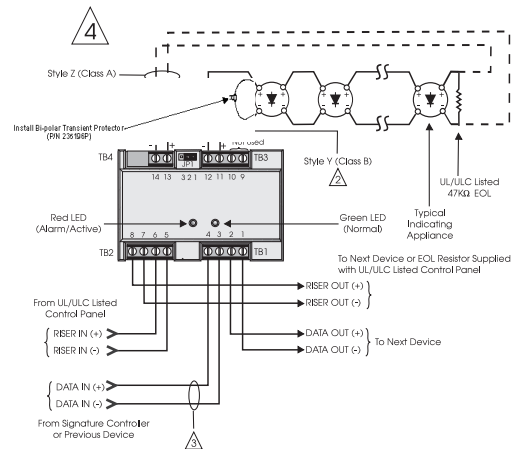

### Class A Single Input Module (Personality Code 9, 10, 11 or 12)

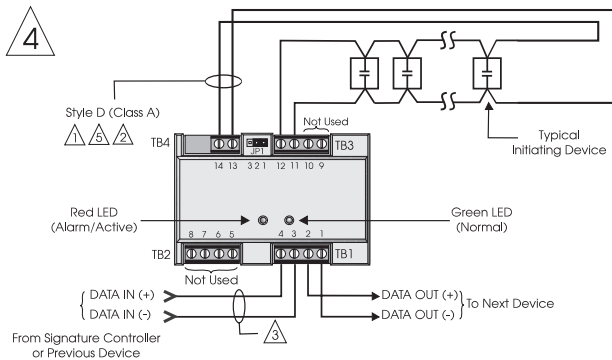

- ⑤ Max. 12.5 ohms resistance per wire for Class A configurations.
- ⑥ Compatible smoke detector. Refer to Personality Codes 13, 14, 20 or 21 for type and quantity.
- ⑦ SIGA-UM must be installed within the same room as the device it is controlling.
- 8) All wiring power limited and supervised. If the input source is non-power limited, then maintain spacing of 1/4 inch, or use FPL, FPLP, FPLR, or equivalent in accordance with NEC.
- 9) Polarity at terminals 11 & 12 shown in Supervisory condition. Connect as shown in diagram. (Polarity reverses on Alarm.)

- ① For maximum wire resistance and maximum wire distances, refer to IOMC Manual (P/N 270144).
- ② Maximum #12 AWG (2.5mm<sup>2</sup>) wire. Minimum #18 AWG (0.75mm<sup>2</sup>).
- ③ Refer to Signature Loop Controller Installation Sheet for wiring specifications.
- ④ This module will NOT support 2-wire smoke detectors unless configured for personality codes 13, 14, 20, or 21.

# Typical Wiring (SIGA-MAB)

Modules will accept #12 AWG (2.5mm<sup>2</sup>), #18 AWG (0.75mm<sup>2</sup>), #16 (1.0mm<sup>2</sup>), and #14 AWG (1.50mm<sup>2</sup>) wire sizes. Note: Sizes #16 AWG (1.0mm<sup>2</sup>) and #18 AWG (0.75mm<sup>2</sup>) are preferred for ease of installation. See Signature Loop Controller catalog sheet for detailed wiring requirement specifications.

## Notification (Output) Module (Personality Code 15 or 16)

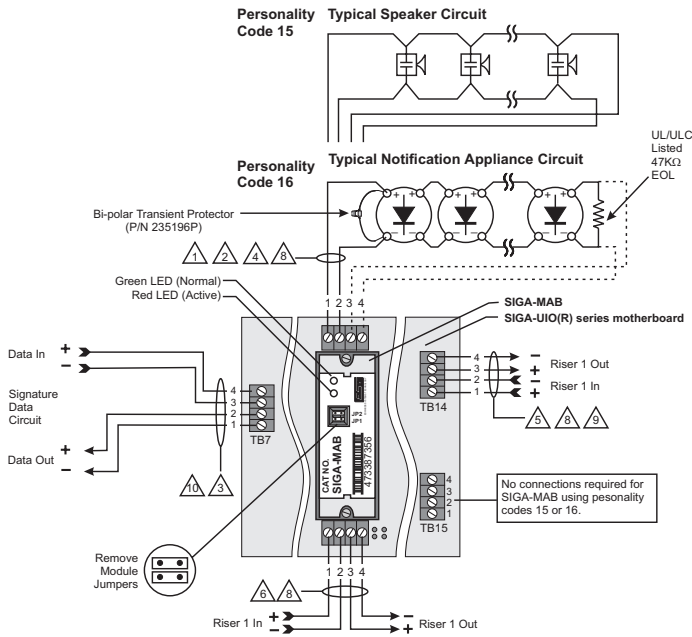

## Class A or B Dry Contact Input Module (Personality Code 1, 2, 3, 4, 9, 10, 11 or 12)

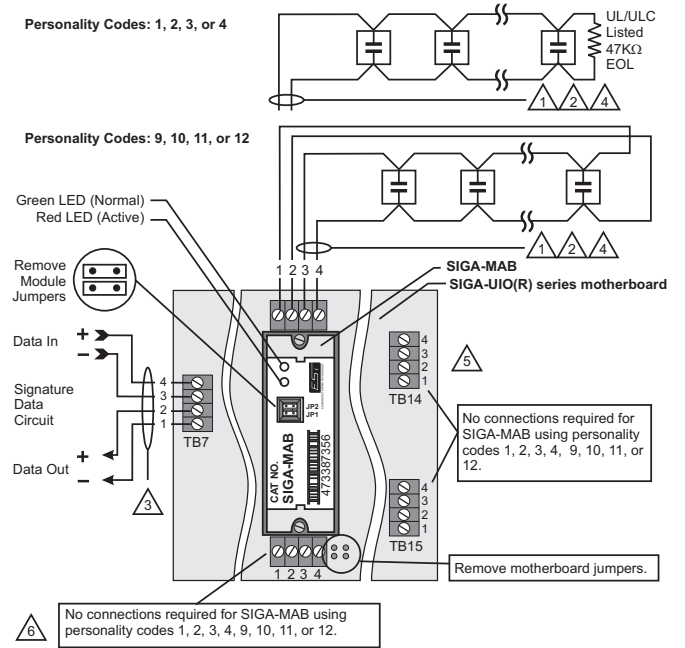

## Class A or B 2-Wire Smoke Detector and Dry Contact Input Module (Personality Code 13, 14, 20 or 21)

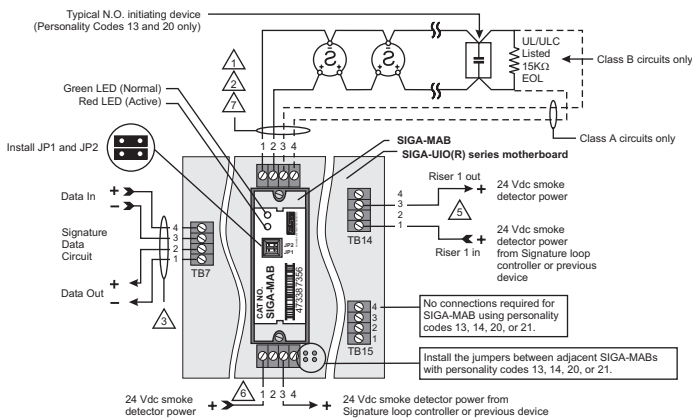

### NOTES

- 1 For maximum resistance, see the appropriate technical reference manual. Maximum circuit capacitance is 0.1 mF.
- 2 Maximum #12 AWG (2.5 mm<sup>2</sup>) wire; Minimum #18 AWG (0.75 mm<sup>2</sup>)
- 3 Refer to Signature Controller Installation Sheet for wiring specifications.
- 4 Maximum 10 Vdc @ 350mA
- 5 The SIGA-UIO6R does not come with TB14.
- 6 The SIGA-UIO6 does not come with TB8 through TB13.
- 7 Supervised and power-limited.
- 8 If the source is nonpower-limited, maintain a space of 1/4 inch from power-limited wiring or use FPL, FPLP, FPLR, or an equivalent in accordance with the National Electrical Code.
- 9 The input for this riser is common to all modules.
- 10 Maximum alarm current is 17 mA. Operating voltage range is 16.0 to 24.0 Vdc.



U.S.  
T 888-378-2329  
F 866-503-3996

Canada  
T 519 376 2430  
F 519 376 7258

Asia  
T 852 2907 8108  
F 852 2142 5063

Australia  
T 61 3 9259 4700  
F 61 3 9259 4799

Europe  
T 32 2 725 11 20  
F 32 2 721 86 13

Latin America  
T 305 593 4301  
F 305 593 4300

www.gesecurity.com

© 2006 General Electric Company  
All Rights Reserved

Signature Series is a Trademark  
of GE Security.

## Specifications

	SIGA-UM	SIGA-MAB
Description	Standard Mount Universal A/B Module	Plug-in (UIO) Universal A/B Module
Wiring Terminations	Suitable for #12 to #18 AWG (2.5 mm <sup>2</sup> to 0.75mm <sup>2</sup> )	
Mounting	North American 2½ inch (64 mm) deep 2-gang boxes & 1½inch (38 mm) deep 4 inch square boxes with two-gang covers and SIGA-MP mounting plates	Plugs into UIO2R, UIO6R or UIO6 Motherboards
Personality Codes	15 Selectable Codes Available	14 Selectable Codes Available
Address Requirements	Uses Two Module Addresses	
Operating Current	See Operating Characteristics Table	
Operating Voltage	15.2 to 19.95 Vdc (19 Vdc nominal)	
Construction	High Impact Engineering Polymer	
Storage and Operating Environment	Operating Temperature: 32°F to 120°F (0°C to 49°C) Storage Temperature: -4°F to 140°F (-20°C to 60°C) Humidity: 0 to 93% RH	
LED Operation	On-board Green LED - Flashes when polled; On-board Red LED - Flashes when in alarm/active	
Compatibility	Use With: Signature Loop Controller	
Agency Listings	UL, ULC, MEA, CSFM	

## Ordering Information

Catalog Number	Description	Ship Wt. lb (kg)
SIGA-UM	Universal Class A/B Module (Standard Mount) - UL/ULC Listed	0.5 (0.23)
SIGA-MAB	Universal Class A/B Module (Plug-in) - UL/ULC Listed	0.18 (0.08)

Related Equipment		
27193-21	Surface Mount Box - Red, 2-gang	2 (1.2)
27193-26	Surface Mount Box - White, 2-gang	2 (1.2)
SIGA-UIO2R	Universal Input-Output Module Board w/Riser Inputs - Two Module Positions	0.32 (0.15)
SIGA-UIO6R	Universal Input-Output Module Board w/Riser Inputs - Six Module Positions	0.62 (0.28)
SIGA-UIO6	Universal Input-Output Module Board - Six Module Positions	0.56 (0.25)
MFC-A	Multifunction Fire Cabinet - Red, supports Signature Module Mounting Plates	7.0 (3.1)
SIGA-MP1	Signature Module Mounting Plate, 1 footprint	1.5 (0.70)
SIGA-MP2	Signature Module Mounting Plate, 1/2 footprint	0.5 (0.23)
SIGA-MP2L	Signature Module Mounting Plate, 1/2 extended footprint	1.02 (0.46)

