

Overview

The DirecDoor™ controller from GE Security is the industry's only 2-reader and 2-door Power over Ethernet (PoE) IP-connected access controller. DirecDoor integrates with GE's Facility Commander™ WNX, Secure Perfect®, and Picture Perfect™ access control and integrated security management software. It can utilize PoE or can be powered by a local power supply. It can even power the lock hardware in its PoE configuration. Its simple plug-in installation significantly reduces labor costs and allows new doors to be efficiently controlled using on-line access systems.

The DirecDoor controller is located on the secure side of the door, thereby providing a much better IP solution than an IP reader. Unlike a less secure IP reader solution, whose Ethernet port, card database and access to the door strike relay lie outside the protected area, the DirecDoor controller significantly reduces the possibility that security could be compromised.

Standard Features

- On board 2-readers with 2 door lock relays
 - Low cost and easy installation
- Support for Weigand and Supervised F/2F
 - Flexibility to use GE Security and other readers
- Intelligence at the edge of the network
 - Database, network connections and lock control connections at the secure side of the door
- PoE and local power supply support for controller and locks
 - Requires fewer terminations resulting in time savings, lower product and installation cost; back-up power for network also backs up controller and locks
- Fire panel alarm connection
 - For additional safety, the DirecDoor controller can be hard-wire connected to the fire alarm system to release door strikes
- Integrated configuration tool based on Web server
 - Remote configuration and ease of set up
- Lower total cost of ownership in low density door environment
 - Allows new doors to be controlled in a cost effective manner.
- Integrates with Facility Commander Wnx, Secure Perfect and Picture Perfect software.

DirecDoor

Power over Ethernet Enabled
Door Controller

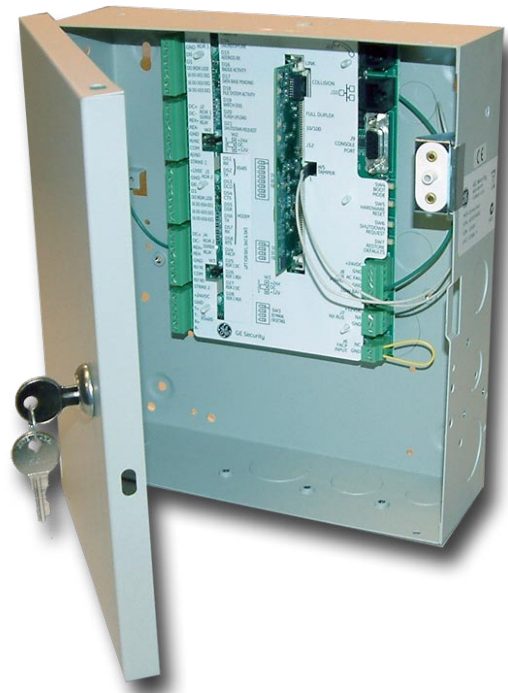

Application

The DirecDoor controller is a full-featured access controller with the feature set defined by the software platform. Up to two doors may be independently controlled. The DirecDoor controller provides connections for two readers (Weigand or Supervised F/2F), two door contacts, two Request-to-Exit (REX) devices and a total of two of either door-strike relays or magnetic lock(s) for a complete installation without the need for any additional expansion hardware.

DirecDoor is equally suitable for new construction or existing installations. On new installations, all doors requiring access control only need to be Ethernet wired. The reader wiring terminates at the door junction box which also functions as the controller. It is therefore only necessary to terminate the wiring once, as opposed to twice, as is required with most other access control systems.

DirecDoor is listed under UL 294, UL 1076, CE and FCC Part 15 Class A.

Associated Equipment*

The DirecDoor controller requires the following associated equipment (one or two of each depending on the number of doors to be controlled): Weigand or Supervised F/2F reader(s), door contact(s), REX device(s), door-strike(s) or magnetic lock(s).

Operation

The DirecDoor controller communicates via TCP/IP network to the host system. Backup communications can be implemented via plug-in dial-up modem. The DirecDoor controller is a fully intelligent controller. Badge database and configuration data is stored in non-volatile memory so the controller can lose power or Ethernet connection temporarily and still retain its database memory. The DirecDoor controller makes real-time access decisions and monitors for alarms.

Dimensions

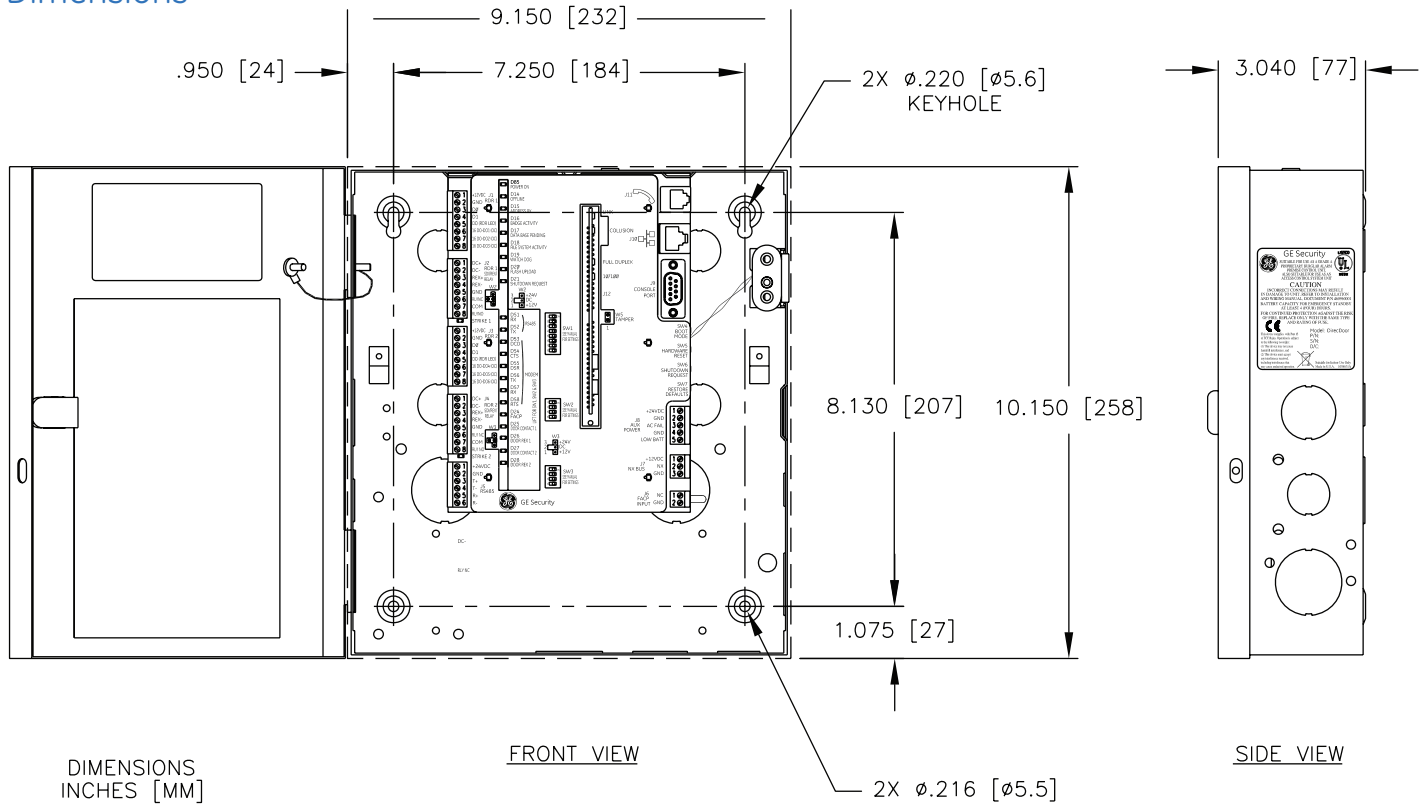

* **Note:** See power budget guidelines for other device capabilities. GE Security can provide a Power Budget Worksheet that can assist in determining if a PoE power supply or local 24 VDC power supply will be needed to power all the desired equipment.

Installation

Traditional Method

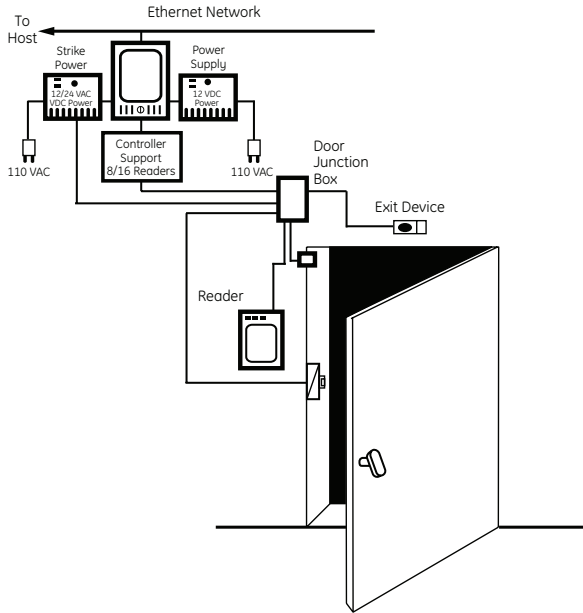

New Method

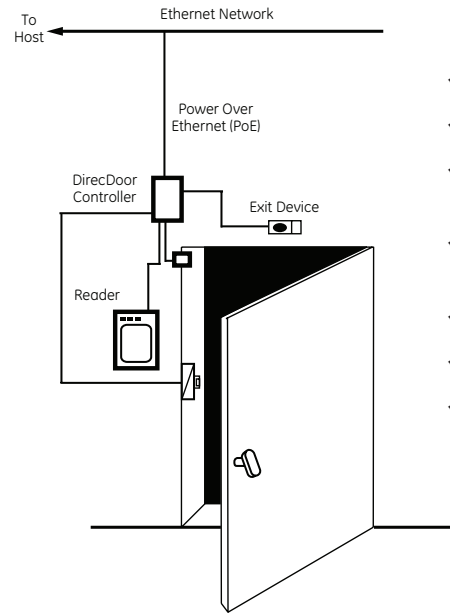

- ✓ Less equipment
- ✓ Fewer terminations
- ✓ Terminate devices once
- ✓ Less wiring (CAT-5 based)
- ✓ Edge of network
- ✓ Full intelligence
- ✓ PoE

Wiegand Wiring - 4 State

(for 2 State omit 1K resistors)

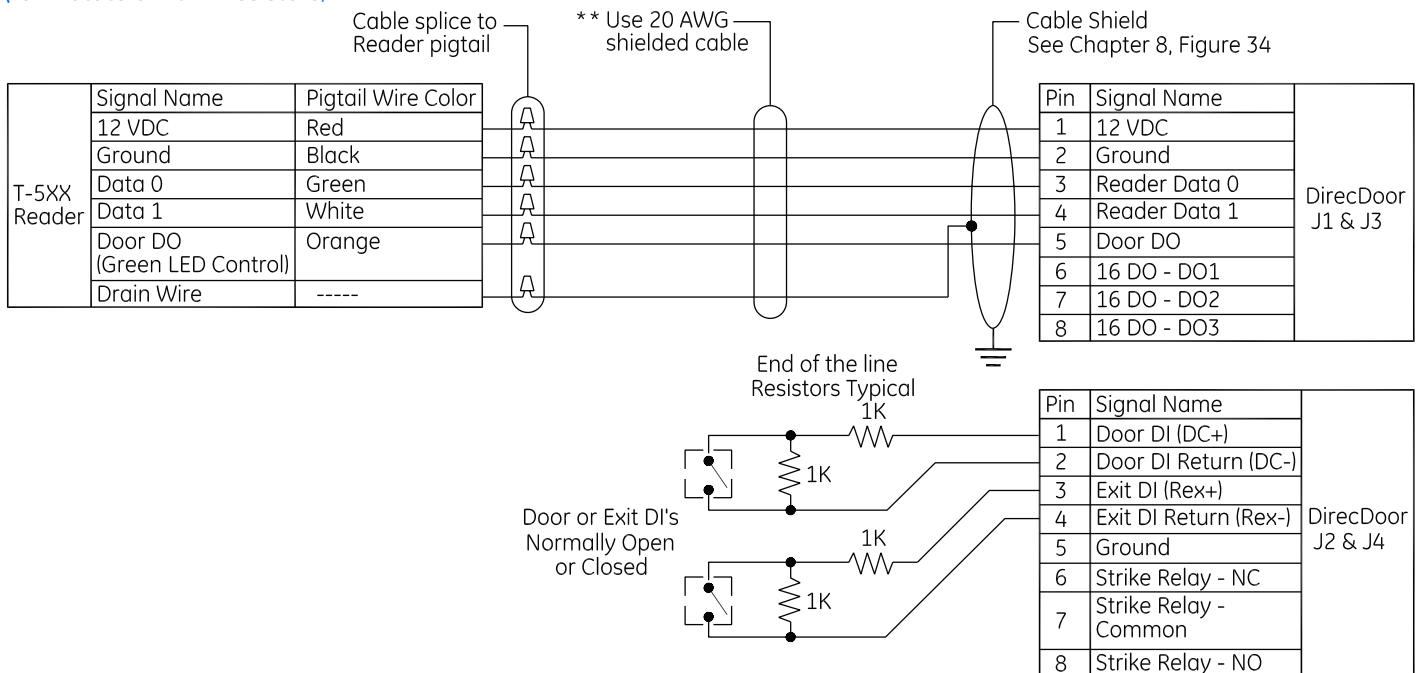

** Use plenum rated cable for applications where cable is to be run above the false (suspended ceiling) in the air circulation space.

North America
T (561) 998-6100
T 888-GE-SECURITY
888-(437-3287)
F 561 998 6224
E rs-bctinfo@ge.com

Asia
T 852-2907-8108
F 852-2142-5063

Australia
T 61-3-9259-4700
F 61-3-9259-4799

Europe
T 32-2-725-11-20
F 32-2-721-40-47

Latin America
T 305-593-4301
F 305-593-4300

www.gesecurity.com

Specifications subject to change without notice.

© 2007 General Electric Company
All Rights Reserved

Specifications

Enclosure Specifications

Physical Dimensions (H X W X D)	10.15" x 9.15" x 3.04" (258mm x 232mm x 77mm)
Operating Environment	+35F to 122F, +2C to 50C
Humidity Range	5% to 95% non-condensing
Thermal air cooling	At least 6" (15.2cm) of clearance is required on all four sides
Field Configurable Options	Optional plug in modem as back-up communication via POTS line
Mounting	Screw mounts to wall

Communications Interfaces

Network	10/100 MB Ethernet, on-board RJ-45 connection, TCP/IP; Supports Static IP or DNS and DHCP
Dial-up (fallback)	Plug-in modem card

CPU Specifications

Operating System	uClinux
Processor	Xlinux
RAM	32 MB
Flash memory	8 MB

Applications supported and capacities

Facility Commander Wnx v7.0 or later AND Secure Perfect v6.1.1 or later

Badge capacity	100,000
Offline badge history capacity	8,192
Offline alarm history	8,192

Picture Perfect 4.x

Badge capacity	145,000
Offline badge history	5,000***
Offline alarm history	2,000***

Picture Perfect 2.x

Badge capacity	200,000
Offline badge history	5,000***
Offline alarm history	2,000***

*** This is default allocation. The capacity can be re-allocated using the Integrated Configuration Tool

Ordering Information

Part Number	Description
DD1FC	DirecDoor Controller, Facility Commander Wnx & Secure Perfect
DD1PP	DirecDoor Controller, Picture Perfect
521247001	Modem, daughter board plug-in, PXNplus CPU & DirecDoor. Field installation required.

